

The Precautionary Principle, the Law of Unintended Consequences, and Biotechnology

Calum G. Turvey, Eliza M. Mojduszka, and Carl E. Pray

Food Policy Institute
Rutgers University

Abstract

The purpose of this paper is to explore within a political economy framework the application of the Precautionary Principle to food and agricultural biotechnology policy. The paper reviews the Precautionary Principle in general, but also raises issues associated with unintended consequences arising from it. In addition, the paper provides a general model of political economy that includes both precaution and consequences, discusses issues related to precaution and irreversibility, and illustrates how unintended consequences can affect social welfare.

Contact Information

Calum G. Turvey
Department of Agricultural, Food and Resource Economics
55 Dudley Road
Rutgers University
New Brunswick, New Jersey 08901

Phone: 732.932.9155 x 224

Fax: 732.932.8887

E-mail: Turvey@aesop.rutgers.edu

Calum G. Turvey is Professor, Eliza M. Mojduszka is Assistant Professor, and Carl E. Pray is Professor in the Department of Agricultural, Food and Resource Economics, Rutgers University

The Precautionary Principle, the Law of Unintended Consequences, and Biotechnology

The Precautionary Principle is increasingly becoming a major tenet of food and agricultural biotechnology policy and a rallying cry by certain environmentalist groups who invariably challenge any changes to the status quo including technological innovations such as genetic modification. Despite significant economic consequences arising from the Precautionary Principle, there has been little analysis done by economists. The purpose of this paper is to present the Precautionary Principle in economic terms. The paper reviews the Precautionary Principle and provides examples of where its consequences have been significant. The paper gives full consideration to the law of unintended consequences and shows the effects of the law on economic outcomes. The paper develops a model of political economy, irreversibility, and then extends the ideas to consider cost-benefit analysis.

The Precautionary Principle

The Precautionary Principle first emerged in Europe in Swedish and German environmental policies in the 1960s and 1970s. In the following years, the principle has been enshrined in many international treaties and declarations (e.g., the 1990 Bergen Declaration on Sustainable Development through the 2000 Cartagena Protocol on Biosafety). The Treaty on European Union (1992), where the words ‘Precautionary Principle’ appeared in the title of the section on environment, provided the basis for common European environmental law as well as environmental health policies. The Treaty, however, did not define the principle in the environment section or anywhere else in the document. The Precautionary Principle was also stated in the 1992 Rio Declaration following the Rio Conference on the Environment and Development. Principle 15 of the Declaration states that: “In order to protect the environment, the precautionary approach shall be widely applied by states according to their capability. Where there are threats of serious or irreversible damage, lack of full scientific certainty shall not be used as a reason for postponing cost-effective measures to prevent environmental degradation.” What this definition of the principle states in two double negatives is that cost-effective prevention of environmental degradation shall not be postponed just because it has not been proven *a priori* that such preventative measures will work. Löfstedt, Fischhoff, and Fischhoff

(2002) report that there exist at least 19 various definitions of the Precautionary Principle used in domestic and international regulatory documents.

Recently, the principle has also morphed into mainstream food and agricultural biotechnology policy through the actions of the European Commission (EC), who in a White Paper on Food Policy (January 1st, 2000) declared that the “use of scientific advice will underpin Food Safety policy, whilst the Precautionary Principle will be used where appropriate”. The foundation of food safety policy was to be based on the three components of risk analysis: risk assessment based on scientific advice and information analyses, risk management based on regulation and control, and risk communication. The White Paper announced that food safety was subject to the Precautionary Principle, however, it was not until a separate Communication issued on February 2nd, where the EC noted that, the Rio Declaration notwithstanding, the Precautionary Principle is not embedded in the Treaty on European Union and relied on legal text, case law and policy orientation. In regards to case law, the Commission noted that the scope of the Precautionary Principle depends on case law, which to some degree is influenced by prevailing social and political values. In regards to policy orientation, the EC made the case on the transitive principle that since the Precautionary Principle is considered in environmental protection, and since environmental protection is tied to the WTO, then the WTO must give due, but non-explicit consideration to the Precautionary Principle¹.

Furthermore, the EC declared that it had the right to establish a level of protection it deems appropriate based on the Precautionary Principle but cannot be used as a form of trade protection. Actions based on the Precautionary Principle must be proportional, non-discriminatory, consistent with similar measures, based on an examination of the potential benefits and costs of action or lack of action, subject to review and revision based on new scientific data, and capable of assigning responsibility for producing the scientific evidence necessary for a more comprehensive risk assessment.

But it is also evident that the application of the Precautionary Principle is subject to political interpretation and influence. The EC Communication also states that the judgment of what is an “acceptable level of risk...is an eminently political responsibility”. The Communication relies heavily on the Agreement on the Application of Sanitary and

¹ For a nice review on the Precautionary Principle and trade agreements see Sheldon (2004)

Phytosanitary Measures (SPS Article 5(7)) to justify its being, but in a much broader context. Risk assessment can be based on non-quantifiable data of a factual or qualitative nature. And in consideration of examining costs and benefits the scope of the Precautionary Principle is very broad and should include non-economic considerations such as the efficacy of possible options and their acceptability to the public. Such principles are to be applied not only to the current generation but future generations as well.

The major controversy around the Precautionary Principle, and its greatest problem as a policy tool, centers on its extreme variability in interpretation. The Precautionary Principle is intended to assess the potential of risk, even if the risk cannot be fully demonstrated or quantified or its effects determined because of the insufficiency or inconclusive nature of the scientific data. Risk assessment is based on four components: hazard identification, hazard characterization, appraisal of exposure, and risk characterization. In regards to these characteristics, scientific uncertainty may arise from the variable chosen, the measurements made, the samples drawn, the models used, the causal relationships employed, controversy on existing data, or lack of relevant data. Notwithstanding scientific protocol, the Commission also admits that it must also respond to varying degrees of public opinion.

The Law of Unintended Consequences

We include in our title the ill-defined law of unintended consequences because we believe that the law and the policy issues about the Precautionary Principle are inextricably linked. The ‘law’ in definition is as ubiquitous as the definition of the Precautionary Principle, but it is also the key motivator for activism and policy action. When the EC states that it will apply the principle for the protection of future generations is it referring to unintended consequences that cannot be rejected with certainty given today’s science? When proponents of the Precautionary Principle lobby for policy change on the basis of scientific uncertainty, is their concern about scientific integrity or the unintended consequences that might come about from that uncertainty? The image portrayed by the term ‘Frankenfood’ is as much about the law as it is about the principle, and perhaps more so.

But the law is nothing new in economics. In resource and environmental economics the term ‘externalities’ has been used for many years to describe the impacts of an action on the welfare of individuals and society. Where it differs is in the use of the term ‘unintended’. An

externality can be intended or unintended, but in the context of the principle, intended and unintended must be segregated. Furthermore, the unintended consequences of a Precautionary Principle can be as much a consequence of invoking the Precautionary Principle as denying it. That is using the unintended consequence of scientific uncertainty to justify the Precautionary Principle may unto itself lead to unintended consequences in other domains.

A possible framework for examining the issue is taken from a statistical perspective with Type I and Type II errors arising from scientific uncertainty. The scientific protocol is to state a hypothesis, which is also a statement about an intended consequence. The intended consequence can be tied to rejection of the null or a failure to reject the null. A scientific test for a nutraceutical for example, will test the null hypothesis that the nutraceutical has no effect on a particular ailment. Rejection of the null is evidence of an intended consequence.

A Type I error arises when the null is rejected but the null is actually true, and a Type II error arises when the null is ‘accepted’, when it should have been rejected. Under Type I error the efficacy of the nutraceutical is not realized in practice. The unintended consequence is that consumers taking the treatment may actually become worse off since they might have shifted reliance to the new treatment at the expense of a more conventional treatment.

The unintended consequence of a Type II error is not so clear-cut. Here, the statistical trials showed no efficacy. But had the product gone to market benefits would have been realized. Since no observations, *ex post*, exist the unintended consequence of a Type II error is rarely observed, but within the economic context of opportunity cost it is no less important. Because only Type I errors are ever observed, much of the Precautionary Principle and the law of unintended consequences relates to Type I error.

The political implications of this are mixed. On the one hand, supporters of the principle argue that the principle is about the burden of proof (Saunders, 2000). Saunders argues that the principle is not about absolute proof that something is safe, but for circumstances in which there is no absolute certainty. Innovators must demonstrate, not absolutely, but beyond a reasonable doubt that the product is safe. He reminds us that under the null, innovators may claim to have proven that something is safe, when in actuality they have failed to prove that it is unsafe. In other words, failure to reject the null does not in itself eliminate Type I error or its unintended consequence. Saunders, further argues, that the general policy, at least within the WTO, is actually an anti-Precautionary Principle; a new product or innovation once proposed, must be

approved unless it can be shown conclusively to be dangerous. The distinction between the Precautionary Principle and the anti-Precautionary Principle is that with the former, the burden of proof is with the innovator; whilst with the latter the burden of proof is with society. The EC Communication in favor of the Precautionary Principle clearly places the burden of proof on the innovator.

The burden of proof under the Precautionary Principle has come under significant scrutiny. Starr (2003) argues that there is no such thing as a Precautionary Principle since there is no analytical basis to support its verification and predictability; it is a rhetorical statement used to justify indefinite deferment of long-term policy measures. If a scientific experiment shows no evidence of long-term harm, it is impossible to predict the possibility of long-term harm; one cannot prove a negative. Likewise, Hathcock (2000) argues that excessive precaution leads to paralysis of action due to unjustified fears. From an economic point of view how portentous is the Precautionary Principle? And is it manageable? Few would argue that in regards to safety and the protection of human and animal health and the environment there is duty of care. Furthermore, where scientific knowledge can be brought to bear on an issue of safety few would argue that it should not be done. Scientific resolve and risk analyses in multi-dimensions and with multiple pathways goes far in determining causality, minimizing Type I and Type II errors and maximizing the ratio of intended to unintended consequences.

Nonetheless, environmentalists, policy makers, politicians and other groups have grasped the Precautionary Principle as a cause *celebré* to justify particular positions they deem important without taking full council on the externality of deferment on others. Hathcock (2000) notes that a slight, but non-zero risk associated with a product or process is far safer than the alternative of doing nothing. In other words, the unintended consequences could be very high when inaction is taken based upon the Precautionary Principle. The policy question then becomes one of rational assessment, which can, from time to time, conflict with or become constrained with the Precautionary Principle.

Impacts of the Precautionary Principle on the Agricultural and Food Sector

This section reviews a case study, where the application of the Precautionary Principle led to very costly unintended consequences. A recent case where the precautionary actions were used to thwart an uncertain outcome, while the unintended consequence was quite certain to

happen, was the 2002 famine in Southern African countries. In the summer and fall of 2002, there were increasing concerns about widespread famine affecting millions of Africans due to drought conditions (The Economist, 2002). The United States, through USAID, offered corn and soybean products to Malawi, Mozambique, Zambia, and Zimbabwe through either a donation or through a loan program that would see the United States advancing funds to purchase U.S. crops. The USAID program, to avoid charges of dumping, requires that the purchases be of equivalent quality as is consumed in the United States. This meant that genetically modified corn and soybeans would be included. Because of fears about the health and environmental risks of GM products, and consequential trade impacts with the EU if donated GM corn was planted and commingled with African maize, the policy was to reject GM foods in African countries (Zerbe 2004)². Opposition came from politicians, scientists, and various organizations within the involved countries as well as European aid groups.

The Southern African countries' position on Genetically Modified Organisms and food aid to Africa is perhaps the best summarized by Magalasi (2003) who reports on behalf of the meeting participants in Malawi on December 11-14, 2002. The report says: "We have observed with disbelief how GMO food aid is being forced on countries facing starvation in Africa. We believe that the whole subject surrounds the issue of choice made by all people in Africa related to Food Sovereignty...We support the recipients country's right to refuse GM food aid as is provided for in the Cartagena Biosafety Protocol, and we call on all donors not to force Africa to choose between starvation and GM food when there is plenty non-GM food, representing 93% of the world food...The forcing of GM food on the poor countries does not recognize the community rights, the rights of the nations, the sustainable availability of local seed variety and long-term implications of genetic engineering...We call on like-minded people who were not present at the meeting in Malawi to join forces in campaigning against the dumping of GMO food (aid) in poor developing countries and support alternative breeding and production methods that benefit the poor. We are determined to see this issue through to the end."

The European aid groups' position can be best represented by a statement made by a spokeswoman for the UK charity ActionAid: "Accepting GM technology now could stop these countries getting back on their feet in the long run" (McDowell 2002). However, in the same

² An extensive political analysis of the 2002 Southern African food aid crisis can be found in Zerbe (2004).

article, an unidentified aid official said of the aid groups encouraging rejection of the US loan “I think it is absolutely irresponsible unless they put their money where their mouth is and come up with non-GM food. I don’t have the nerve, heart or soul to deny, as a Precautionary Principle, food to people who are hungry right here, right now. It is a debate that only America and Europe can afford because they have food”.

Undoubtedly, the controversy surrounding the Southern African GM food aid centers on diametrically different approaches to the interpretation and use of the Precautionary Principle and regulation of genetically modified crops and food in the European Union and the United States. The European Union and the United States do not interpret and use the Precautionary Principle in the same way (Sheldon 2004). More specifically, the United States reasons that by ensuring that GM crops and food are ‘substantially equivalent’ to existing conventional crops and food, there is no basis to apply the Precautionary Principle. Under this argument, the solution is that GM crops and food should not be subjected to standards any different from conventionally produced crops and food. It is also noteworthy that the United States is not a signatory to the Cartagena Biosafety Protocol. The European Union, on the other hand, reasons that because of the Precautionary Principle, GM crops and food should be subjected to separate standards and regulations. Ultimately, a compromise was reached in the Southern African GM food aid case with the governments of Malawi, Mozambique, and Zimbabwe. To avoid starvation, the United States and its aid workers accepted a proposal from South Africa that would send only milled corn (corn powder) to the three African countries. The compromise was not reached with the government of Zambia. In addition, later and well into the crisis, the European Union agreed to provide funds to purchase non-GM food (from South Africa and India) to aid the remaining Southern African nations affected by the famine.

The African experience provides a very good example of how controversial and misrepresented the Precautionary Principle can be. In this story, the aid workers, those sent to assist in famine relief, could have been forced to accept widespread famine, starvation and death with certainty, in favor of an unproven, undocumented, and undefined future risk. It is unlikely that the architects of the Precautionary Principle had this interpretation in mind. Clearly, the approach adopted by the EC made allowances for exceptions when unintended consequences were known with reasonable certainty. This is not to say that the Europeans would accept GM crops from Africa, had seed been delivered and planted (the intended consequence), but from a

political point of view, it is unlikely that they would have raised the threat under the Precautionary Principle to purposefully thwart aid efforts and knowingly subject Africans to a known risk.

The Political Economy of the Precautionary Principle

When scientific uncertainty exists, how should policy makers respond? Should policy makers incorporate the direct economic costs of their actions in the decision-making process and risk assessment? And should they also incorporate into the analyses the unintended consequences? In this section, we present a model of political economy that helps address these dilemmas and to cast light on the multifaceted issues and complexities involved in the risk assessment and decision making process.

The model we present assumes that experimental protocols and risk assessments have been met to scientific standards but that in the absence of scientific certainty there remains a probability P that the product can at some future date cause harm to humans, animals or the environment. Critics of GM foods, for example, will argue that in the absence of long-term longitudinal testing, science cannot ‘prove’ with certainty that a product is safe³. To counter scientific uncertainty, the Precautionary Principle brings about a policy regime, defined by θ , to balance uncertainty about future hazards occurring at some unknown time, T , based on information available at time t . The benefits of the policy will only be recognized if the event occurs at T with probability P , but in the meantime there may be some direct economic costs of implementation, $C_0(\theta) \geq 0$. The optimum policy is determined by maximizing the expected social welfare function,

$$(1) \quad E[W] = [P(\theta, t)W_1(\theta, T) + (1 - P(\theta, t))W_0(\theta, t)]e^{-\lambda T} - C_0(\theta)$$

where $P(\theta, t)$ denotes the probability of hazard assigned to scientific uncertainty; $(1 - P(\theta, t))$ is the scientific certainty known at time $t < T$; $W_1(\theta, T)$ is the economic welfare that will arise if a future hazard at T occurs; and $W_0(\theta, t)$ is the economic welfare that would occur in the present time based on scientific knowledge. Since future concerns over potential hazards give rise to precaution then it must be true that $W_0(\theta, t) > W_1(\theta, T)$. Economic welfare in this case can be

³ This model was inspired from ideas presented in Glauber and Narrod (2001) who in turn cite Rendleman and Spinelli (1999).

considered as the net consumer and producer surplus under the two regimes. In the extreme, $W_0(\theta, t)$ becomes the economic welfare in an embargoed state due to the Precautionary Principle since, under the principle, the product (that at some future date can cause harm) is effectively banned. The benefits of the Precautionary Principle will only be ‘realized’ in the future so the benefits are discounted by the social discount rate λ . Later, the social discount rate plays an important role in determining the optimum policy because different groups of individuals may have differing time preferences for uncertainty. If λ represents the willingness to wait for scientific certainty, a population with few options to wait will discount the future benefits at a much higher rate than a population with many options. In fact, λ becomes an important political variable since proponents of the Precautionary Principle who have the least to lose by delaying an action become the ‘policy makers’, while those who have the most to lose become the ‘policy takers’. It is the difference in welfare between the ‘policy makers’ and the ‘policy takers’ that define the unintended consequence of the policy.

The optimal policy decision is obtained by taking the derivative of expected welfare with respect to the policy parameter, θ , and setting it equal to zero.

$$(2) \quad \frac{\partial W}{\partial \theta} = \left[\frac{\partial P}{\partial \theta} (W_1 - W_0) + \left(\frac{\partial W_1}{\partial \theta} P + \frac{\partial W_0}{\partial \theta} (1 - P) \right) \right] e^{-\lambda T} - \frac{\partial C_0}{\partial \theta} = 0.$$

There are two distinct outcomes to the calculus. The bracketed term represents the benefits of the policy and the second term represents the costs to the policy. The benefits are comprised of two elements. First, by delaying the introduction of a new product it is hoped that scientific uncertainty is reduced. Hence, $\partial P / \partial \theta \leq 0$, which reduces the likelihood of the welfare loss $(W_1 - W_0) < 0$. The second component represents the improvement in welfare in each state. By applying the Precautionary Principle the intent is that should a hazard occur, loss is mitigated and therefore $\partial W_1 / \partial \theta \geq 0$. The effect of the policy on W_0 is ambiguous with $\partial W_0 / \partial \theta \leq 0$ being possible. In the state of nature that supports the original scientific assessment it is possible that $\partial W_0 / \partial \theta > 0$ if by delaying introduction, consumer confidence increases. This is possible using the credence attributes discussed by Caswell and Mojduszka (1996). Using that framework, asymmetric information between the market and the science may affect consumer choices.

Within the context of a Precautionary Principle, consumers may deem the good safer at time T than at time t because any ambiguity about probability of harm (and hence the asymmetry in information) has been largely diminished⁴. If $\partial W_0/\partial\theta$ in (2) is zero then consumers' consumption and expenditures on the good will be the same at time T as it would have been at t. But $\partial W_0/\partial\theta$ may also be negative indicating that invoking a Precautionary Principle diminishes confidence, or lowers the credence value in the safety of the good, even if time has shown that it is actually safe. If it is negative consumer perceptions of the credence variables will be lowered. Regardless, an optimum policy based upon the Precautionary Principle will be one in which a change in expected welfare is non-negative.

The role of time and time preference is provided in equations (3) and (4).

$$(3) \quad \frac{\partial W}{\partial T} = -\lambda [PW_1 + (1-P)W_0] e^{-\lambda T} < 0,$$

$$(4) \quad \frac{\partial W}{\partial \lambda} = -T [PW_1 + (1-P)W_0] e^{-\lambda T} < 0.$$

In either case, welfare is reduced in matters of time. Equation (3) states that the longer it takes to resolve scientific uncertainty the lower will be the welfare benefits of the policy. Equation (4) states that the higher the time preference for the targeted product the lower will be the welfare effect. In addition, Equations (5) and (6) show the rate at which marginal welfare changes with respect to time, T, and social discount rate, λ . In both cases, marginal welfare decreases.

$$(5) \quad \frac{\partial^2 W}{\partial \theta \partial \lambda} = -T \left[\frac{\partial P}{\partial \theta} (W_1 - W_0) + \left(\frac{\partial W_1}{\partial \theta} P + \frac{\partial W_0}{\partial \theta} (1-P) \right) \right] e^{-\lambda T} < 0,$$

$$(6) \quad \frac{\partial^2 W}{\partial \theta \partial T} = -\lambda \left[\frac{\partial P}{\partial \theta} (W_1 - W_0) + \left(\frac{\partial W_1}{\partial \theta} P + \frac{\partial W_0}{\partial \theta} (1-P) \right) \right] e^{-\lambda T} < 0.$$

⁴ Within the general context of food safety research, credence attributes usually refer to or arise from asymmetric information between consumers and producers (see Caswell and Mojduszka, 1996). Here we use the terminology and context to describe market behavior (which includes both consumers and producers as defined for W) when full information is unknown about the science.

Combined, equations (3) through (6) show that the effectiveness of a Precautionary Principle cannot lie in isolation of exogenous variables such as need on the part of consumers or society and the time for which scientific uncertainty is resolved. The question is whether or not there is a balance between the assessment of risk and the underlying policy. In theory, there is a policy that occurs when θ is chosen, such that the marginal benefits equal marginal costs as in equation (7);

$$(7) \quad \left[\frac{\partial P}{\partial \theta} (W_1 - W_0) + \left(\frac{\partial W_1}{\partial \theta} P + \frac{\partial W_0}{\partial \theta} (1 - P) \right) \right] e^{-\lambda T} = \frac{\partial C_0}{\partial \theta}.$$

Social optimality of a Precautionary Principle must account for all of the variables. On the right hand side are the direct costs of the policy. These costs could include lost investment opportunities, lethargy in research and development, lost economies to the intended recipients of the scientific research, and any compensation to the industry as a result of the policy. On the left hand side are the expected marginal social benefits of delaying the commercial attributes of scientific discovery. The social benefits are driven by a number of factors, including the probabilities associated with scientific uncertainty. The greater the scientific uncertainty then the greater will be the marginal benefits from applying the Precautionary Principle. But in addition, the policy must take into consideration the severity of the welfare impacts. The Precautionary Principle can reduce welfare in the current state and impose an externality on the economy.

The social discount rate, λ , is also critical since it reflects the importance of the scientific discovery to a population or group. To many, in fact the majority, λ , might be small. In agriculture, certain input traits to improve milk production or reduce pest infestations do not directly enter consumer utility and therefore consumers would be willing to wait longer for the resolution of uncertainty. On the other hand, populations in need of genetically modified foods to stave off famine, or to develop medicines from genetically engineered plants will discount the benefits of future research more highly. In other words, the benefits of waiting become lower for these inflicted groups.

Should the Precautionary Principle take into account the needs of different populations? Consider two populations identical in all respects except that the benefits of waiting are lower

for one group than another. Then $W(\lambda_1) < W(\lambda_2)$ if $\lambda_1 > \lambda_2$. This is the unintended consequence. In the case of food aid for African famine relief, it was the Precautionary Principle based on European standards discounted at λ_2 that caused delays in food aid to the Southern African nations. The populations in those nations, facing certain death in many instances, were not in a position to wait for scientific uncertainty to be resolved. To a cohort facing starvation $\lambda_1 \rightarrow \infty$, and $W(\lambda_1) \rightarrow 0$. Defining $C_1(\theta, \lambda_1 - \lambda_2)$ as the shadow cost of time preference then

$$(8) \quad \left[\frac{\partial P}{\partial \theta} (W_1 - W_0) + \left(\frac{\partial W_1}{\partial \theta} P + \frac{\partial W_0}{\partial \theta} (1 - P) \right) \right] e^{-\lambda T} = \frac{\partial C_0}{\partial \theta} + \frac{\partial C_1}{\partial \theta}.$$

Equation (8) is a restatement of equation (7) excepting that the policy should also include, as part of its cost measure, the unintended consequence on different populations. The inevitable consequence of such a proposition is that inclusion of the unintended consequence associated with θ will require a new equilibrium. If including the unintended consequences of the Precautionary Principle causes marginal costs to rise above marginal benefits, then θ should be relaxed and the Precautionary Principle should be relaxed.

Finally, there are some implications for future research in this area. In our modeling, we do not endogenize individual risk perceptions and social risk preferences. These are exogenously given and enter our model indirectly through the λ variable. In their recent work, Slovic et al. (2000) investigated cross-cultural risk perceptions of nuclear power in the United States and France. Their work provides the basis for understanding public responses to nuclear power risks and, as a result, how the communication of risk between technical experts, policy makers, and the public can be improved. The main result of the study is that the public's understanding of risk is much broader, richer than technical experts'. Therefore, risk communication and management methods, in order to be successful, must be structured as a "two-way" process. Experts and policy makers must account for and respect "the intelligence" of the public. The authors do not model individual risk perceptions and public preferences in the economics framework. This means that the authors do not specify utility functions and are unable to estimate social welfare changes resulting from various valuations of nuclear power. There also exist a few studies that investigate individual risk perceptions and public preferences of agricultural biotechnology (e.g., Hallman et al 2003). It appears that even in countries where governments have been supportive of the GM technology, public lack of support will most likely

continue to have a huge impact on the future of GM food and crops (Sheldon 2004). To extend our model and endogenize individual risk perceptions and public preferences, it would be necessary to model explicitly product and consumer characteristics and then aggregate preferences over individuals to be able to estimate and evaluate social welfare changes.⁵

Irreversibility and the Precautionary Principle

It has been argued that irreversibility and uncertainty can be used to justify the Precautionary Principle (Gollier and Treich 2003). In fact, from an economic point of view, irreversibility provides a natural segue to the Precautionary Principle and greater precaution should be taken with increased uncertainty. Such an assessment is agreeable, but only when the costs and benefits are evaluated without prejudice to intended and unintended consequences. In fact, the rule in (8) is very much consistent with the literature on irreversibility and precaution.

Irreversibility as a conceptual basis for economic and policy analysis derives originally from an investigation into the role of uncertainty in the development of a natural area by Arrow and Fischer (1974). Irreversibility refers to the ability to undo a previous action when it turns out that the social benefits of such an action are outweighed by the social costs. If there is uncertainty as to whether the social costs will ultimately be higher or lower than the social benefits, then there exists an option to postpone economic development (as in the case of Arrow and Fischer 1974) or commercialization of a scientific discovery (as in the case of Gollier, Jullien and Treich, 2000) until uncertainty is resolved. If uncertainty is never resolved, then postponement could be infinite, but the optimal timing is also weighted towards the degree of irreversibility. The easier a decision can be undone the lower will be the option value to postpone a decision. Uncertainty and irreversibility therefore work in tandem; the degree of uncertainty increases precaution, while the degree of reversibility decreases it. They are not mutually exclusive.

Should public policy based upon the Precautionary Principle take into consideration the reversibility of a previous decision? It would appear, as Gollier and Treich (2003) point out, that the Precautionary Principle is economically justified if and only if the decision is irreversible. Is

⁵ To date, we have applied discrete choice techniques to examine consumer perceptions of the nutritional quality of food products and policy implications (Mojduszka et al. 2003).

food policy reversible? The answer is obviously an empirical one, but in many cases the answer is probably yes. Seed stores can be used to rapidly supplant GM crops; ecological habitats surrounding farm fields can be developed to maintain fluid populations of indigenous species; rotations between GM and non-GM crops can be used to thwart resistance. But, what about the unintended consequences? Death due to starvation because of an embargo on GM foods is irreversible but the policy itself is reversible.

<<< FIGURE 1 ABOUT HERE >>>

The relationship between options values, unintended consequences, and irreversibility is illustrated in Figure 1. A choice from two mutually exclusive paths must be considered. The upper path represents an embargo while the lower path represents an unrestricted market, which we refer to as the free state. Consider the embargo decision first. At node 1) an intended consequence of β_1 is realized with probability $(1-\rho_1)$ while an unintended consequence occurs with probability (ρ_1) . If ρ_1 occurs a proportion of the population, n_1 , is negatively affected. The welfare loss in this state is given by: $(1-n_1) B_1 - n_1 C_1$, where $n_1 C_1$ represents the cost to the afflicted community. But the unintended consequence may be reversible with probability ρ_2 . If it is reversible then some portion of the afflicted population, m_1 , can be restored, for a recovery of $m_1 (n_1 C_1)$ but at a cost Y_1 . The net welfare is $W_{11} = (1-n_1) n_1 C_1 - Y_1$ with conditional probability $\rho_1 \rho_2$. If the unintended consequence is irreversible then the net welfare is $W_{12} = (1-n_1) \beta_1 - n_1 C_1$ with conditional probability $\rho_1(1-\rho_2)$. We can write the expected welfare from the embargo decision as

$$(9) \quad W_1 = (\rho_1 \beta_1 + \rho_1 \rho_2 [(1 - n_1) \beta_1 - (1 - m_1) n_1 C_1 - Y_1] + \rho_2 (1 - n_1 C_1) .$$

If the market is unrestricted, the new product can be sold. At node 3, scientific certainty reveals that a benefit β_2 will occur with probability $(1-\rho_3)$. Scientific uncertainty is measured with probability ρ_3 , and if ρ_3 occurs, the whole population is afflicted, resulting in a social cost C_2 . If this is reversible, then, going from node 4 some portion of the population, m_2 , can recover but at a cost of Y_2 . The benefit of reversibility is $m_2 C_2$ and the net welfare cost of the unintended consequence is $W_{21} = -((1- m_2)C_2 + Y_2)$ with conditional probability $\rho_3 \rho_4$. If the consequence

cannot be reversed then with probability $\rho_3(1-\rho_4)$, the welfare impact is $W_{22} = - C_2$. The expected welfare from the free state is

$$(10) \quad W_2 = (1-\rho_3) \beta_2 - \rho_3 \rho_4 ((1 - m_2)C_2 + Y_2) - \rho_3(1 - \rho_4) C_2.$$

The policy to embargo based upon the Precautionary Principle has a positive option value if $W_2 > W_1$ and the value of the option will be $W_2 - W_1$.

The model considered by Gollier et al. assumes that $\rho_1 = 0$ so that the benefit of the embargoed state is $W_1 = \beta_1 \geq 0$ and occurs with probability 1.0. This is weighed against the expected costs of the free market given by $-\rho_3(\rho_4((1 - m_2)C_2 + Y_2) - (1 - \rho_4)C_2)$. From this we can visualize the significance of irreversibility. Suppose that the unintended consequence is reversible with probability $\rho_4 = 1$. If all afflictions can be reversed ($m_2 = 1$), then only the cost Y_2 remains. If reversibility is costless ($Y_2 = 0$) the option disappears. But full consideration of an unintended consequence in the embargoed state can also extinguish any option values brought about by the Precautionary Principle. This is especially true when the unintended consequence occurs with a high probability. In the case of the Southern African nations, considering the probability (ρ_1) of famine (C_1) afflicting a large population (n_1) should have extinguished any option values attributable to the Precautionary Principle.⁶

From an economic perspective, the Precautionary Principle imposes a constraint on an economic system. Conventional optimization of utility or profits holds that a constraint, when binding, imposes economic or social costs. But in the context of the Precautionary Principle, these have to be weighed against social benefits. The model presented in the previous section can be cast in the context of the Coase theorem, under which social welfare is optimized when the marginal benefits of an action equals the social benefits. The theorem is depicted in Figure 2.

<<< FIGURE 2 ABOUT HERE >>>

⁶ In our modeling, we do not consider a possible option of non-GM food aid. But, it is worth to point out that several months passed before the non-GM food aid was made available. During that time, affected populations experienced starvation or even death.

In Figure 2, the X axis represents the unknown future risk associated with a food product to which the Precautionary Principle is applied. Because the food product or technology might include some unforeseen or unproven risk, invocation of the Precautionary Principle will require establishing a standard that matches societal benefits with societal costs. Such benefits and costs need not be denominated in money terms. Marginal benefits can be measured in terms of increased marginal utility. The social optimum will define the regulatory standard where the marginal societal benefits equal the marginal costs of the principle. This occurs for θ_{low} at point A on the cost curve labeled ‘unintended consequences’ which includes both intended and unintended costs (C_1 and C_2 in equation (8)). On the other hand, if the regulatory authority recognizes only the intended costs (C_1 in equation (8)), the optimum policy would be an abatement strategy, θ_{high} at point B. However, failing to recognize the unintended consequences the true marginal societal costs at the prescribed standard would, at the intersection at point C, be much higher than those believed to be true at point B. Relaxing the standard from θ_{high} to θ_{low} does not provide the same (perceived) social benefit as the original standard based upon the Precautionary Principle, but society as a whole is better off when unintended consequences are taken into account. When Zimbabwe’s President Mugabe relaxed the restriction on importing GM food, imposed on the basis of the Precautionary Principle, averting the unintended consequence of mass famine resulted in an overall increase in social welfare relative to what would have occurred had the Precautionary Principle remained rigid.

Conclusions

This paper examined some of the economic consequences of the Precautionary Principle. In particular, this paper focused on the law of unintended consequences and argued that for the Precautionary Principle to be fairly applied it must also consider the law of unintended consequences. The political economy model shows that a simple framework of cost-benefit analyses may not be entirely correct if it only examines the direct effects of the intended policy. In many instances, such as the recent debate over US aid of GM grains to alleviate famine in Malawi, Mozambique, Zambia, and Zimbabwe the Precautionary Principle was taken to such an

extreme that proponents were willing to sacrifice African lives with near certainty in order to protect local crops and possible exports against GM pollution claims that could not be disproved with scientific certainty. How could this happen? Under the political economy model presented, the welfare of society is based upon an optimum policy that balances the social welfare based on scientific knowledge against the unknown welfare effects arising from scientific uncertainty. The welfare effects of the policy diminish with scientific certainty, but an important component of the presented model is the recognition that the benefits of the policy occur only at some future (but unknown) date and only if welfare losses result from the original scientific uncertainty. But the benefits are not uniformly distributed across all populations. As in the case of the Southern African nations, postponing food aid until such a date that all scientific uncertainty was resolved was not an option. In the extreme, the Precautionary Principle applied to uncertainty about the long-term effects of GM crops would have had the unintended consequence of many African deaths with near certainty.

The paper also discussed the reversibility of scientific uncertainty. Under some strands of this literature, the Precautionary Principle is justified under the flexibility or option value it provides to postpone the marketing of some goods. But, the option value diminishes significantly if either reversibility in the unintended consequence assigned to scientific uncertainty is high, or the costs from irreversible unintended consequences arising from precaution are high. In either case, food policy must not only consider unintended consequences of Type I and Type II error, but must also consider, if at all possible, their degree of reversibility.

Unintended consequences may lead to errors in public policy. Without considering the unintended consequences, the assigned costs associated with the Precautionary Principle would be much lower, leading to more stringent enforcement. However, it was shown, at least theoretically, that when considering the costs associated with unintended consequences, the optimum strategy would be to reduce control.

There are of course instances in which history through hindsight would have welcomed the Precautionary Principle (e.g. asbestos). However, the text of this paper argues that proponents of the Precautionary Principle must look beyond the mere measurement of scientific uncertainty to consider fully and completely the opportunity and societal costs of the law of unintended consequences.

References

- Arrow, K.J. and A.C. Fischer (1974) "Environmental Preservation, Uncertainty and Irreversibility" Quarterly Journal of Economics 88:312-319.
- Caswell, J. A. and E. M. Mojduszka. 1996. Using Informational Labeling to Influence the Market for Quality in Food Products. American Journal of Agricultural Economics, 78(December):1248-1253.
- Commission of the European Communities (2000) "White Paper on Food Safety" COM (1999) 719 Final, Brussels: CEC.
- Commission of the European Communities (2000) "Communication From the Commission on the Precautionary Principle" COM (2000) 1 Brussels: CEC.
- Food and Agriculture Organization and World Health Organization (1997) Joint FAO/WHO Expert Committee on Food Additives, June 17-26 1997, Rome.
- Glauber, J.W. and C.A. Narrod (2001) "A Rational Risk Policy for Regulating Plant Diseases and Pests" Regulatory Analyses 01-05, AEI-Brookings Joint Center for Regulatory Studies, June.
- Gollier, C. and N. Treich (2003) "Decision Making Under Scientific Uncertainty: The Economics of the Precautionary Principle" Journal of Risk and Uncertainty 27(1):77-103.
- Gollier, C., B.Jullien and N.Treich (2000) "Scientific Progress and Irreversibility: An Economic Interpretation of the Precautionary Principle" Journal of Public Economics 75:229-253.
- Hallman, W. K., W. C. Hebden, H. L. Aquino, C. L. Cuite, and J. T. Lang (2003) "Public Perceptions of Genetically Modified Foods" Research Report, Food Policy Institute, Rutgers, The State University of New Jersey, New Brunswick, NJ (available at <http://www.foodpolicyinstitute.org>).
- Hathcock, J.N. (2000) "The Precautionary Principle: An Impossible Burden of Proof for New Products" Ag-Bio-Forum 3(4):255-258.
- Löfstedt R., B. Fischhoff, and I. R. Fischhoff (2002) "Precautionary Principles: General Definitions and Specific Applications to Genetically Modified Organisms" Journal of Policy Analysis and Management 21: 381-407.
- Magalasi, C. (2003) "GE/GM Food Aid" Review of African Political Economy, Vol. 30(95): 162-165, March.

- Majone, G. (2002) “What Price Safety? The Precautionary Principle and Its Policy Implications” Journal of Common Market Studies 40(1):89-109.
- McDowell, N (2002) “ Africa Hungry for Conventional Food as Biotech Row Drags On” Nature 418:571-572.
- Mojduszka, E. M. (2003) Endogenous Consumer Preferences and Knowledge About Nutrition. Selected Paper presented at the Annual Meetings of the *American Association of Agricultural Economics*, Montreal, Quebec, August 3-6.
- Otsuki, T, J.S. Wilson and M. Sewadeh (2001) “Saving Two in a Billion: Quantifying the Trade Effect of European Food Safety Standards on African Exports” Food Policy 26:495-514.
- Rendleman, C.M and F.J. Spinelli (1999) “The Cost and Benefits of Animal Disease Prevention: The Case of African Swine Fever in the U.S.” Environmental Impact and Assessment Review 19:405-426.
- Saunders, P.T. (2000) “Use and Abuse of the Precautionary Principle” Institute of Science in Society Submission to US Advisory Committee on International Economic Policy (ACIEP) Biotech. Working Group, 13 July.
- Sheldon, I. (2004) “Europe’s Regulation of Agricultural Biotechnology: Precaution or Trade Distortion?” Journal of Agricultural and Food Industrial Organization, Vol. 2: 1-26.
- Slovic, P., Flynn J., Mertz C. K., Poumadere M., Mays C. (2000) “Nuclear Power and the Public, A Comparative Study of Risk Perceptions in France and the United States”, in O. Renn and B. Rohrman (Eds), *Cross Cultural Risk Perceptions*, Kluwer Academic Publishers, Dordrecht/Boston/London.
- The Economist (2002) “Hunger in Southern Africa: Can Famine Be Averted?” 3rd August:38-39.
- Starr, C. (2003) “ The Precautionary Principle Versus Risk Analysis” Risk Analysis 23(1):1-3.
- United Nations (1992) “Rio Declaration on Environment and Development” The United Nations Conference on Environment and Development, Rio de Janeiro, June 3-14, (www.unep.org).
- Zerbe, N. (2004) “Feeding the Famine? American Food Aid and the GMO Debate in Southern Africa” Food Policy 29:593-608.

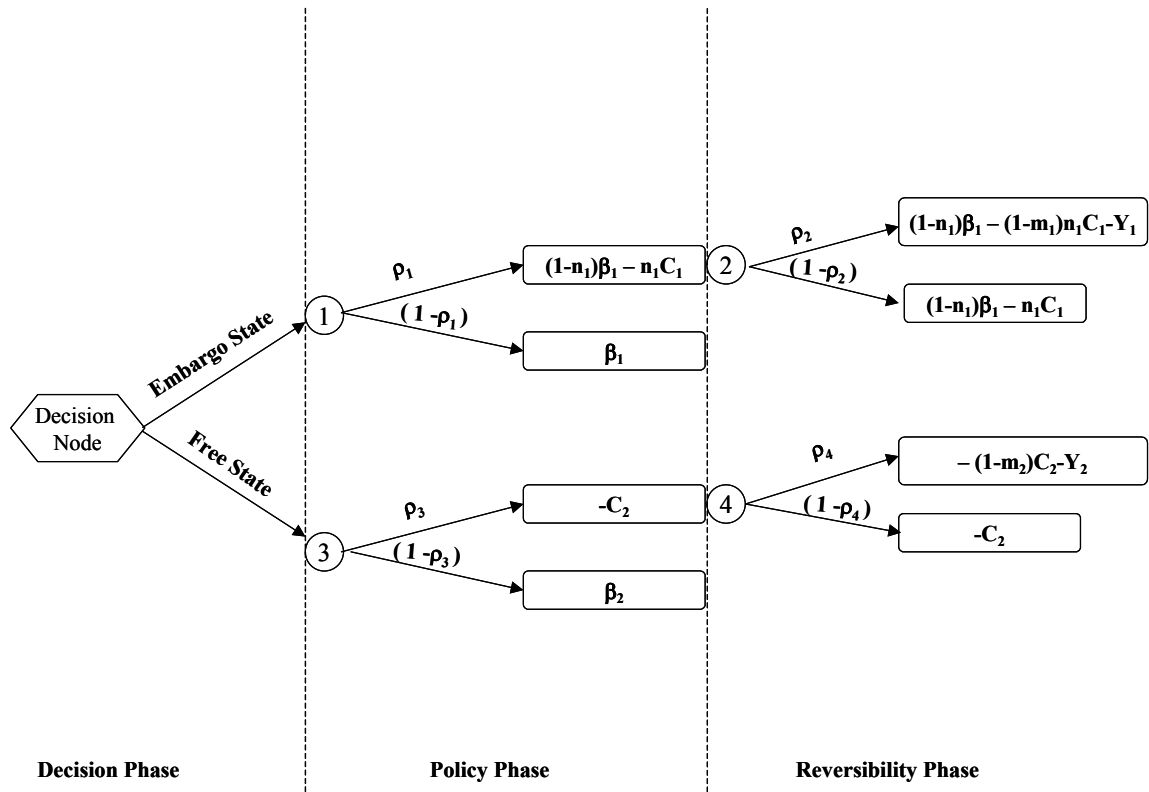

Figure 1: Irreversibility and the Precautionary Principle

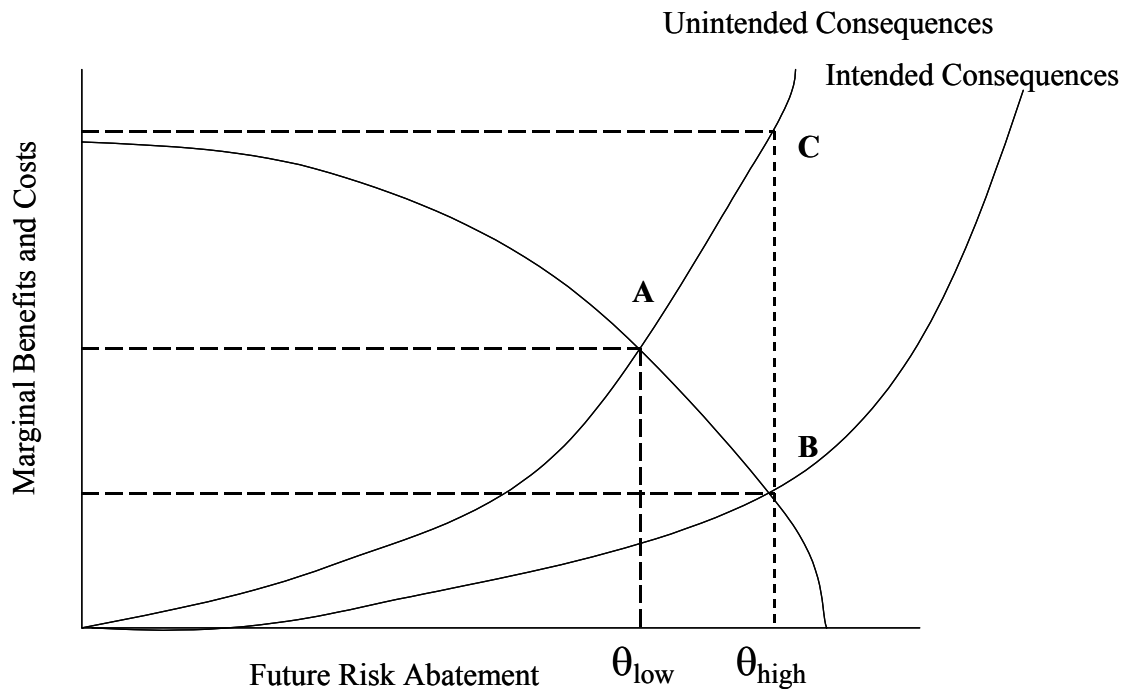

Figure 2: Coase Theorem Applied to the Precautionary Principle